

EASYWEIGH

BY **MIR** 

VC800 VERTICAL INLINE CAPSTAN



Contents

Introduction	Page 3
Important Information Safe Operation	
Installation	Page 5
Capstan Location, Handy Hints and Electrical information	Page 6
Circuit breaker Deck switch Isolating switch Batteries Rotation Solenoid Installation	
Wiring Layout	Page 8
Troubleshooting	Page 9
Line Care	Page 10
Operating Instructions	Page 11
Drawings	
Electrical	Page 13
Maintenance Schedule	Page 16
Warranty	Page 17



BUILT TO LAST SINCE 1968 2



INTRODUCTION

Thank you for purchasing a Muir Capstan. Muir go to great lengths to develop anchoring and berthing systems that not only meet all your performance and safety requirements, but at the same time designed with a style and finish that enhances the aesthetics of your vessel. With Muir's commitment to quality and use of superior materials and processes we know you will be pleased with your investment, and rest assured that through the correct installation, operation, and maintenance your new Muir Windlass will give you years of reliable performance.

SIGNAL WORDS

WARNING:

The signal word **WARNING** indicates a dangerous situation that, if not prevented, can lead to a severe injury or death.

CAUTION:

The signal word **CAUTION** indicates a dangerous situation that, if not prevented, could directly lead to or result in damage to or destruction of the equipment.

IMPORTANT INFORMATION

CAUTION: To avoid damage to the gear drive, windlass or vessel when pulling hard on the capstan, it is a preferred practice to manage the load on the ropes by varying the pull on the tail. If the operator finds the capstan laboring excessively, they should reduce the pull on the tail and allow the rope to slip a little.

CAUTION: Windlasses and mooring capstans must have pressure relief valves installed in the case of a hydraulic drive or an appropriate capacity circuit breaker in the case of an electric drive.

CAUTION: If anchor retrieval or capstan pull is impaired by high wind, heavy seas or the anchor is snagged, ease the load by using motors and or thrusters etc. to move the boat in the intended direction rather than total reliance on the winch or capstan to do all the work.

WARNING: Warranty will be voided if the vessel lays directly on the anchor windlass without a chain stopping device engaged, or if mooring ropes are directly loading the capstan rather than being transferred to a bollard.

WARNING: Under no circumstances should the windlass or capstan be operated if it is stalled or overloaded.

SAFE OPERATION

Read all safety instructions and information. Failure to comply with safety instructions and information may lead to property damage, serious injuries, or death.



BUILT TO LAST SINCE 1968 3



EASYWEIGH SERIES – CAPSTAN VC800

INTENDED USAGE

This product is exclusively intended for the application as a mooring capstan and as agreed on at the time of quote and order. Any other or extended form of use does not comply with this definition of intended use. The intended use includes compliance with this documentation and other applicable documents to avoid malfunctions and damage in operation.

The product in its delivery status is safe to operate. However, the product may pose dangers if improperly used by unauthorized, untrained, and uninstructed staff or if not used according to its intended use.

GENERAL SAFETY NOTES

The anchoring and mooring systems are very high load bearing and extremely powerful pieces of mechanical equipment. Extreme caution must be taken when operating these systems, and only trained personnel who have reviewed this manual shall be permitted to use them.

Key safety risks include, but are not limited to:

- Crush points between highly loaded rope/chain and the equipment
- Entanglement in rotating equipment (capstan, gypsy/ chainwheel etc.)
- Impact risks from chain and rope whip due to uncontrolled chain/rope release through improper use of the capstan/windlass.
- Impact risks from chain/rope whip due to misaligned equipment.

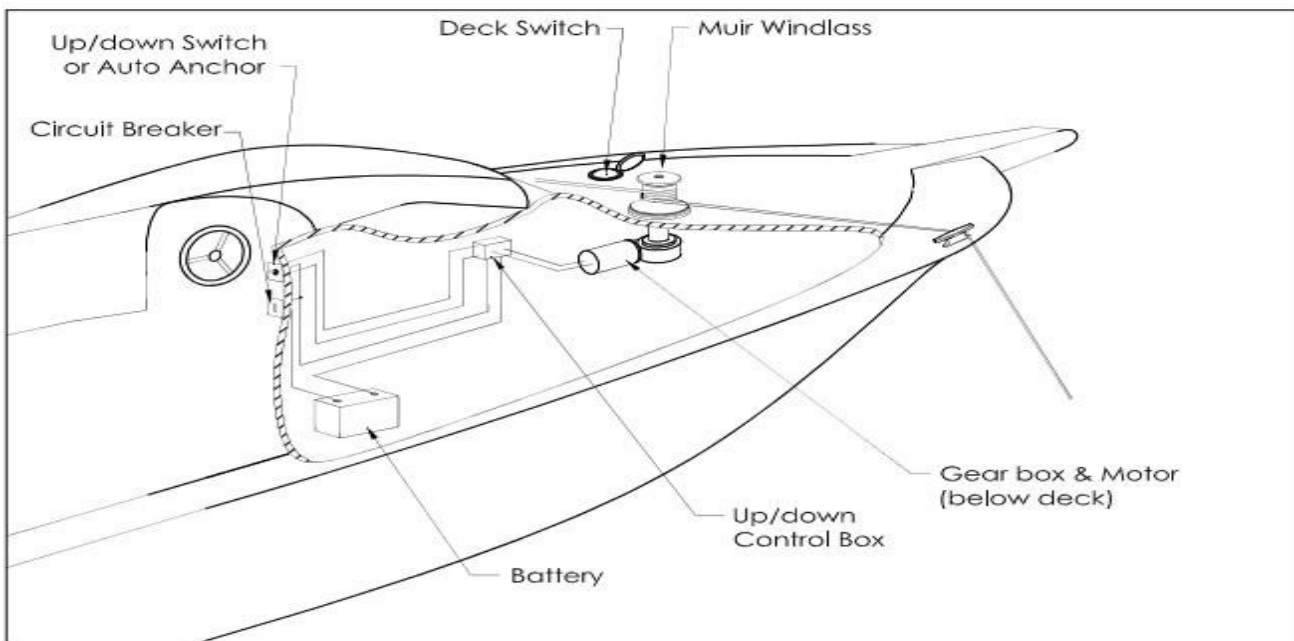

WARNING: Failure to review and abide by this document for the correct installation, commissioning, operation, and maintenance of the equipment will increase the likelihood of the above risks.

Note that figures might deviate from the product and are not drawn to scale. No conclusions can be drawn with regard to size and weight.



BUILT TO LAST SINCE 1968 4



INSTALLATION INSTRUCTIONS

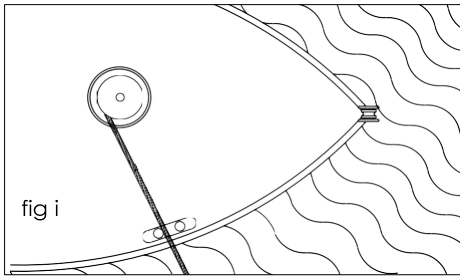

Figure(i)

Locate the capstan in a suitable position on the deck so there is no interference from other ropes or objects. Ensure that the rope has a clear lead to the capstan. Make sure that the capstan is in a position so that the rope source is as close to perpendicular as possible. Ensure that there is sufficient room to run the electrical cables or hydraulic lines to the capstan underneath the deck.

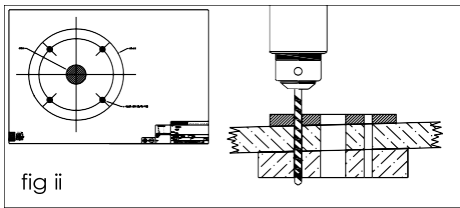

Figure (ii)

If the deck is angled (fore & aft) or curved (port to starboard) a suitably shaped mounting block will be required to spread the load evenly over the deck surface and mount the capstan base on a level and even footing. Depending on the thickness of the deck, a suitable spacer below deck may be required to mount the winch.

Place the shaped mounting block (if required) onto the deck. Using the layout template supplied, mark the mounting centres and drill the holes. Dissassemble the capstan components for installation.

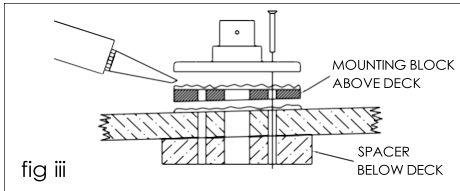

Figure (iii)

Apply an appropriate sealant to the base plate and mounting block (if required), taking care to align mounting holes when assembling. For Aluminium or Steel hull vessels, it is important to insulate the capstan with a non-conductive gasket to avoid corrosion. This also applies below deck with the mounting bolts, nuts and washers. Where the deck construction is light or of foam sandwich construction, a plywood stiffener of at least 16mm (5/8") should be fitted to the underside of the deck to spread the load.

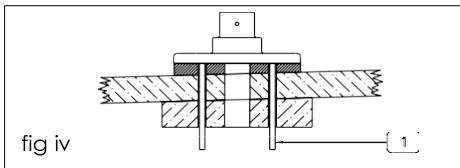

Figure (iv)

Place the base mounting screws into the holes.

1. Check that there is enough thread through the spacer below deck for securing.

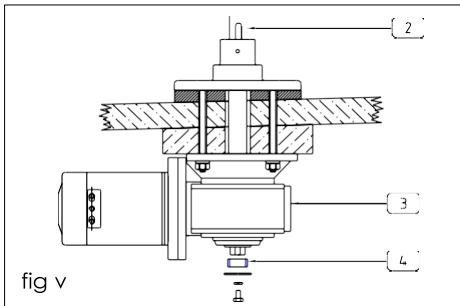

Figure (v)

2. With the shaft in place for proper alignment.

3. Slide the motor / gearbox in place, secure washer and nut on each bolt and tighten. Check that the shaft has free movement and is not jammed on the gearbox key after tightening the screws. Remove excess sealer.

4. Fit a suitable size spacer to the shaft protruding from gearbox, then fit the two washers and fixing bolt to the shaft.

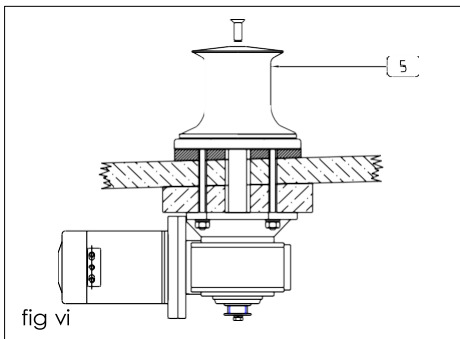

Figure (vi)

5. Grease shaft and key, slide Capstan onto shaft ensuring key is aligned and screw capstan onto shaft. Check that the shaft has approximately 0.5mm up/down movement and the capstan is not jammed to the base after tightening the screws.



CAPSTAN LOCATION

Capstans should generally be located near the aft quarter of the vessel close to bollards or cleats and appropriate fair leads. The capstan should be aligned so that the mooring ropes can easily lead from the fairlead on to the bottom of the capstan drum for ease of wrapping the rope around the drum 3 or 4 times. Once the capstan has been utilized to draw in the mooring line, the rope should be unwrapped from the drum and directly cleated off nearby. Full wind loads of the mooring lines should not be applied directly to the capstan.

HANDY HINTS

It is a common mistake to utilise non stretch ropes such as Dyneema for mooring lines. However stretchy rope with some give (Like Nylon or Polyester) is greatly preferred because the give in the rope reduces maximum loads on equipment and cleats etc.

Rope for mooring lines should also be sized appropriately and flexible enough to contact well around the capstan drum thereby creating the necessary friction to pull the line in without too much slippage (again a problem with non-stretch ropes such as Dyneema is that they slip very easily on the capstan drum).

It is also a common mistake to use the capstan and then cleat off the rope without removing the rope from the capstan drum. As a result, full mooring loads and high wind loads will be applied to the drum and shaft of the capstan.

WARNING: Using capstan and then cleating off the rope without removing the rope from the capstan drum will void warranty.

ELECTRICAL

See Wiring Diagrams for wiring instructions.

WARNING: INCORRECT WIRING CAN LEAD TO FAILURE OF WINDLASS AND SEVERE INJURY OR DEATH DUE TO POTENTIAL FIRE HAZARD.

Circuit breaker (must be fitted to ensure warranty)

If the windlass is overloaded or stalled the circuit breaker automatically cuts off power to the windlass and protects the wiring and motor. The circuit breaker should not be used as an isolating switch, purely for safety reasons.

Deck Switches are best located out to either port or starboard or directly behind the windlass in a position where it can be easily reached with your foot or knee, preferably where you can view the anchor and chain coming aboard.

Isolating Switch should be fitted in an accessible position for safety, ideally close to the battery or switches. The isolating switch is not a circuit breaker.

Batteries are best located as close to the windlass as possible. Larger cables will reduce the voltage drop to the motor and the heat generated when running the windlass. Small diameter cables drop voltage considerably. Use the following table as a guide to your required wire size:

Distance from battery to motor (m)	Cable Size (mm ²) AWG	Cable Core Diameter (mm)
< 7 (23')	16 5	5 (13/64")
8 – 11 (26' – 36')	25 3	7 (17/64")
12 – 16 (39' – 53')	35 2	8 (5/16")



BUILT TO LAST SINCE 1968 6



EASYWEIGH SERIES – CAPSTAN VC800

Rotation: Windlasses may be wired for single or dual direction, using single or dual deck switches for raising or lowering. Alternatively, a remote-control solenoid packages with Toggle Switch, Hand Pendant or Auto Anchors are available.

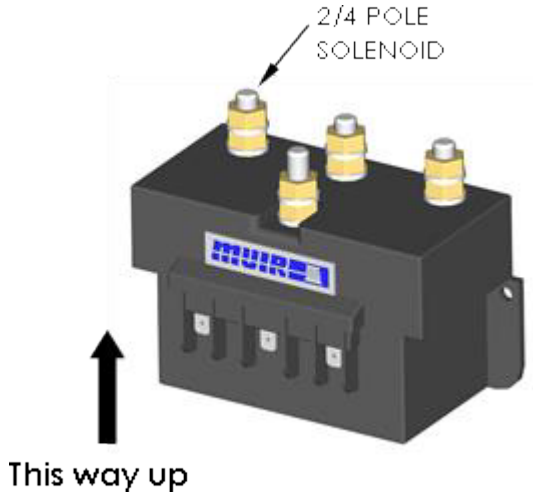

Solenoid Installation (Required for Deck Switches)

We recommend that the solenoid is installed in an upright position, where it has minimal exposure to sea water and in close proximity to the electric motor of the windlass/capstan.

A Remote Switch may be used with or without a solenoid for the WINDLASS.

For wiring information, please refer to the appropriate wiring diagram.

WINCH MODEL	MOTOR SIZE	MOTOR TYPE
VC 500	200 / 600W	2 POLE
VC 650	600W	2 POLE



BUILT TO LAST SINCE 1968 7



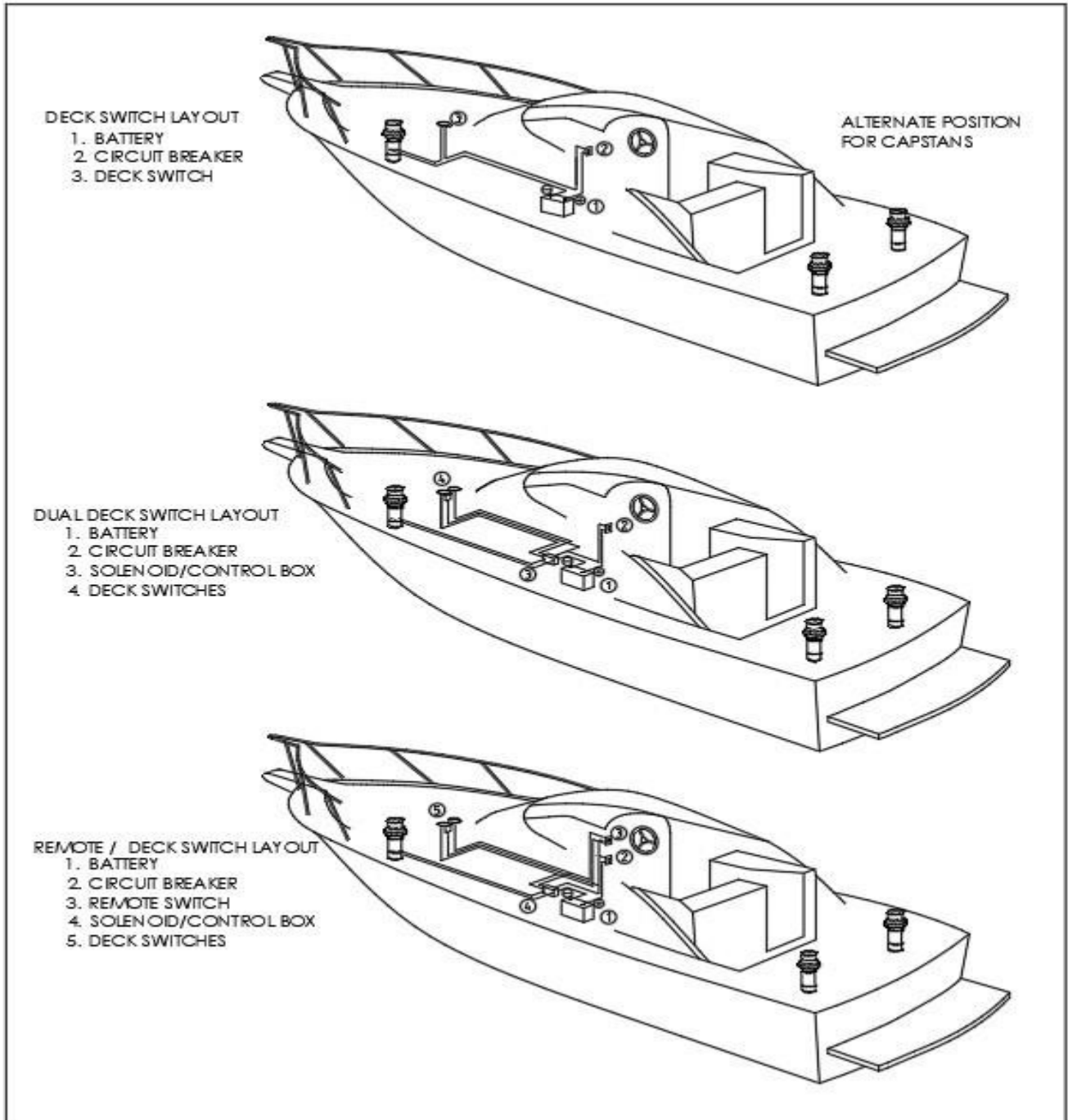

CAUTION: NOT TO BE USED AS WIRING DIAGRAMS



BUILT TO LAST SINCE 1968 8



Trouble Shooting

ELECTRICAL

1. Check the battery circuit breaker and ensure the isolating switch is on.
2. Check battery is charged up to 12 or 24 volts.
3. Check that the foot switch plunger is contacting.
4. Check remote control solenoid is contacting, if this is clicking the problem may be low voltage a faulty solenoid or a wire not properly connected or tightened.
5. Check wiring between controls, solenoid and motor are intact.
6. If the motor will not turn after checking the above points check that the motor bushes are not worn or sticking.

MECHANICAL

If the windlass/capstan running gear will not turn or operate check the following

1. Check the drive key between the gearbox and motor input.
2. Check the drive key on main shaft to capstan.
3. Check the drive key on main shaft to gearbox output.
4. Check that the clutch above the chain gypsy (Windlass only) is tightened to the chain gypsy drive using the manual handle supplied.
5. If the line slips check the tension on the finger and increase spring tension.

HYDRAULIC MOTOR

Refer any problems with your hydraulic motor to a Muir service agent or Muir Hobart.

FREEFALL MECHANISM (For Freefall Anchor Winches only)

1. Check that the freefall plunger and spring can move freely.
2. Ensure that the declutcher pawl is in the correct position and that the grub screws holding this in place are tightened.



BUILT TO LAST SINCE 1968 9



Line Care (For Rope/Chain Gypsies only)

Using the wrong type of line may cause the line to jam causing excessive line wear. Muir Windlasses are designed to run on a 3-strand nylon line (supplied by Muir) which has been specially treated with fabric softener to prevent it from hardening. It is recommended to soak your rope in fresh water containing fabric softener every 3 months.

In case of a rope jam, slacken off the windlass clutch to free the jammed line. When retrieving the anchor rode do not continue to run the windlass if the anchor or chain is jammed, as line slippage in the gypsy will cause damage to the line.

Rope/Chain Splice.

1. To stop rope unravelling, seize rope 400mm(16") from end with whipping twine. Unlay strands.
2. After placing 20mm (3/4") of heat shrink sleeve tubing through the last link of chain, pass one strand of rope through sleeve and chain from one side and the other two strands of rope from the opposite side. (See illustration).
3. While pulling all three strands tight, shrink the sleeve tightly onto the rope using a hairdryer / fan heater or by immersing in boiling water.
4. Remove seizing and complete back splice in normal manner for two full tucks. With a hot knife pare down the three strands by 1/3 and insert two further tucks. Pare down by another 1/3 and finish with two tucks. Cut any remaining tails.

CAUTION: POOR SPLICING OF ROPE TO CHAIN WILL LEAD TO REDUCED OR UNACCEPTABLE PERFORMANCE OF THE ROPE CHAIN MANAGEMENT SYSTEM

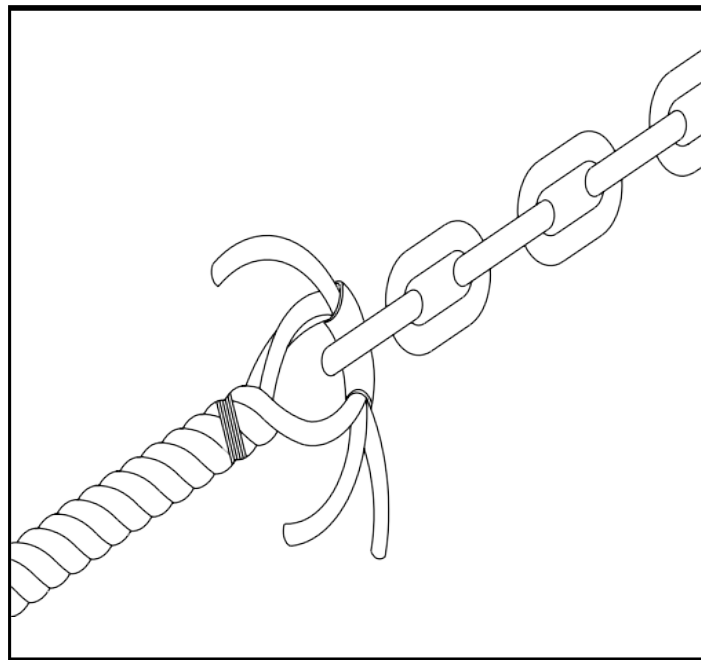

VC800

OPERATING INSTRUCTIONS

WARNING: Always keep well clear of the capstan drum when releasing or retrieving rope and/or anchor chain. Keep fingers, hair, and clothing well clear when the windlass or capstan is in operation, particularly around areas where the rope and/or chain enters and leaves the capstan/gypsy. There is a high risk of crush or entanglement injuries in these areas.

Manually releasing Rope: To release the mooring line, simply reduce the tail load and allow the rope to slip around the capstan drum. If faster line out speed is required quickly unwrap the rope from around the drum and let it out faster.

Anchoring: When laying at anchor use a chain stopper, nylon/chain bridle or snubber line to prevent snatching and direct loading on the windlass main shaft. If the capstan is being used for retrieval of an anchor on smaller boats, ensure that the chain fixing the anchor to the rope does not wrap around the capstan as it will cause damage.

CAUTION: Never use the windlass or capstan as a mooring bollard! Always use a snubber line or chain stopper to take the load of the chain off the windlass.

Retrieving chain: Before operating the windlass tighten the clutch with the handle in a **clockwise** direction, then remove the handle. If the anchor is buried hard, secure the line to take the load off the windlass and motor forward to pull the anchor free.

Electric operation: Releasing and retrieving the Anchor rode is identical when operating the windlass. To release the anchor down, reverse the motor by pushing remote switch to "down" which drops the chain and the anchor immediately. When the anchor is at the desired depth, the windlass can be stopped by letting go of the switch, the chain and rope can then be lowered further by releasing the manual clutch.

CAUTION: Do not activate the UP & DOWN foot switch at the same time. Motor damage may result from switching operation of the capstan when the motor is running in the other direction.

Anchor Launching: If the anchor roller can be positioned so that the anchor falls as soon as the windlass is reversed, the whole operation can then be carried out remotely. Remote switching controls are self-centering and stop the windlass when the switch is released. Mark the anchor end of the line at 2 and 5 metre (6.5' & 16.5') intervals to enable the operator to judge when the anchor is almost up.

CAUTION: Go slowly for the last few metres of retrieval by letting go of the switch, rather than waiting for the anchor to fly up over the roller and pull tight, this will put excessive load onto the bow roller, windlass/capstan and fore deck so should be avoided.



BUILT TO LAST SINCE 1968 11



OPERATING DIAGRAM

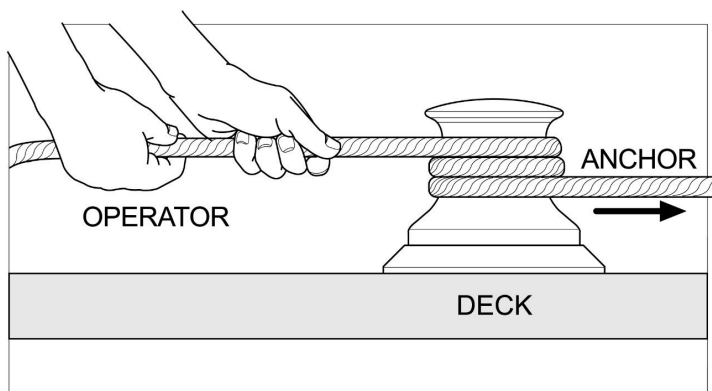

To operate the capstan, wrap the rope around the drum 3 or 4 times and operate the switch while maintaining a load on the tail of the rope.

CAUTION: When lifting light loads such as smaller anchors or sails, three or four turns around the Capstan is sufficient. Heavier loads will require additional turns for added grip and less chance of slippage.

SERVICING

The gear drive is filled and sealed at factory with long life synthetic oil and does not require regular replacement. Rinsing all deck gear with fresh water after every excursion ensures that salt deposits and corrosion are kept to a minimum. We recommend the windlasses of Pleasure Vessels are stripped yearly and all moving parts cleaned and greased with a Marine Grease, Teflon or Lithium based grease (e.g., Shell Gadus S220). In the case of Work and Charter Vessels, we suggest it is carried out more frequently.

ATTENTION!

VC800 Capstan will ONLY work in clockwise direction.

Always connect Positive (+) Terminal on the Battery to the Positive (+) Terminal on VC800 Electric Motor. Always connect negative (-) Terminal on the Battery to the negative (-) Terminal on VC800 Electric Motor.

**If wired incorrectly it will damage
the Electric Motor and VOID the Warranty**



BUILT TO LAST SINCE 1968 12



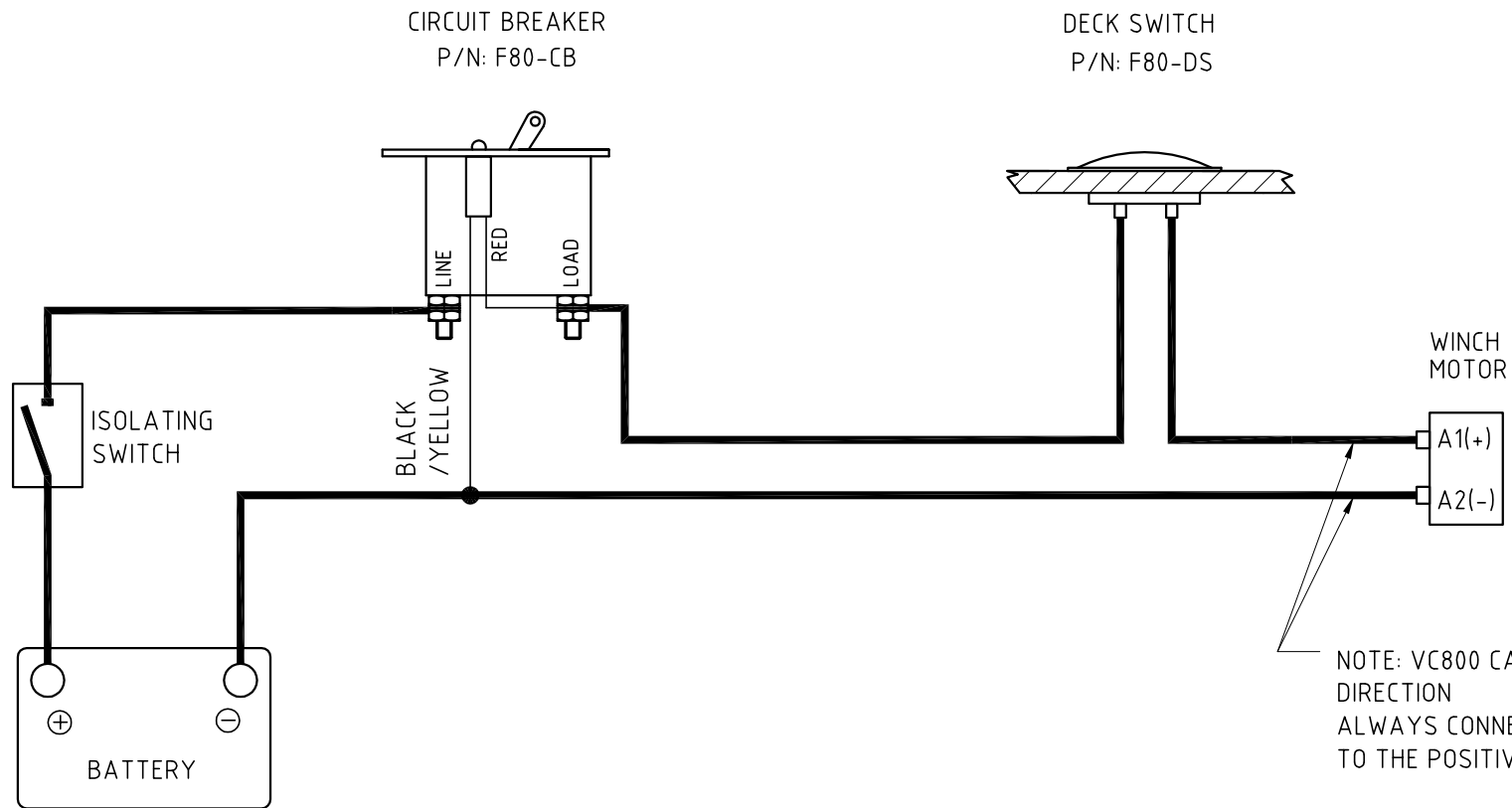

NOTE: VC800 CAPSTAN WILL ONLY WORK IN CLOCKWISE DIRECTION
 ALWAYS CONNECT POSITIVE (+) TERMINAL ON BATTERY TO THE POSITIVE (+) TERMINAL ON THE MOTOR.

ALWAYS CONNECT NEGATIVE (-) TERMINAL ON BATTERY TO THE NEGATIVE (-) TERMINAL ON THE MOTOR.

IF WIRED INCORRECTLY IT WILL DAMAGE THE MOTOR AND VOID THE WARRANTY

FOR OTHER CAPSTANS: FOR ANTI-CLOCKWISE OPERATION REVERSE THE WIRES GOING TO THE 'A1' & 'A2' TERMINALS

WARNING !!
 DO NOT ACTIVATE THE UP & DOWN DECK SWITCHES AT THE SAME TIME. REFER TO MANUAL FOR MORE INFORMATION

— REFER TO MANUAL FOR WIRING INDICATED BY HEAVY LINES
 — LIGHTER LINES INDICATE LIGHT WIRING.

NORMALLY APPLIES TO THESE WINCHES AND MOTORS

MOTOR 12/24V	200W	600W
WINCH MODEL	VC 500	VC 650/VC800

MUIR WINDLASSES AUSTRALIA

TITLE TWO TERMINAL MOTOR (SINGLE DIRECTION) WIRING DIAGRAM (SINGLE DECK SWITCH)			
PART No.			
DRN SA	DATE 24/03/95	DRG No. WIRE0006	
SCALE NTS	APP1	APP2	SIZE A4

TOLERANCES (mm)	
X.	±
X.X	±
X.XX	±
UNLESS OTHERWISE SPECIFIED	
MATERIAL	
FINISH	

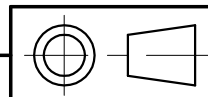

JAS-ANZ

 DNV Certification Pty Ltd
 Quality Assured
 ISO9001

G:\Acad\Wiring\WIRE0006.dwg_18/11/2013 11:18:36 AM, panos

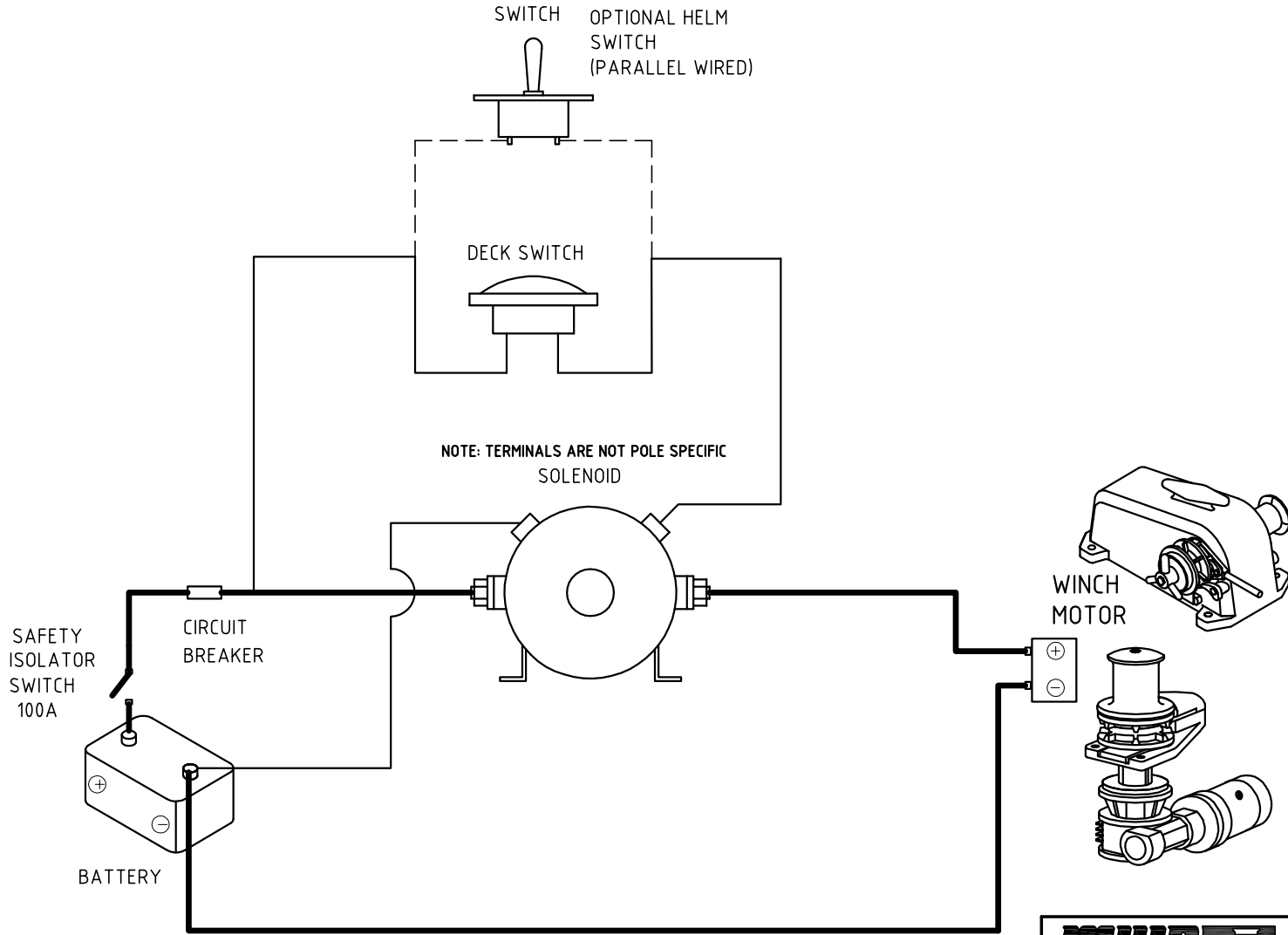
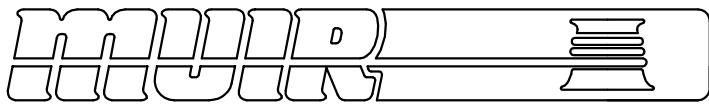

×HEAVY LINES INDICATE BATTERY CABLE. (HIGH AMP)
 LIGHTER LINES INDICATE WIRING. (LOW AMP)
 DASHED LINES INDICATE OPTIONAL WIRING

TOLERANCES (mm)	
X.	± 0.5
X.X	± 0.1
X.XX	± 0.025

UNLESS OTHERWISE SPECIFIED

MATERIAL

FINISH



TITLE
 SINGLE SOLENOID, SINGLE DIRECTION, SINGLE SWITCH
 (POSITIVE ACTIVATING)

PART No. WIRE0007 PAGE 1 OF 2

DRN SA	DATE 22/05/95	DRG No. WIRE0007
SCALE NTS	APP1	APP2
		SIZE A4

© COPYRIGHT MUIR ENGINEERING PTY. LTD.

G:\Acad\Wiring\WIRE0007.DWG, 18/11/2013 1:18:10 PM, pomus

JAS-ANZ

DNV Certification Pty Ltd
 Quality Assured
 ISO9001

REV No. 1	DESC. TABLES REMOVED
-----------	----------------------

BY. PG DATE. 18/11/2013

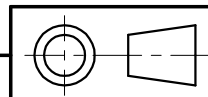

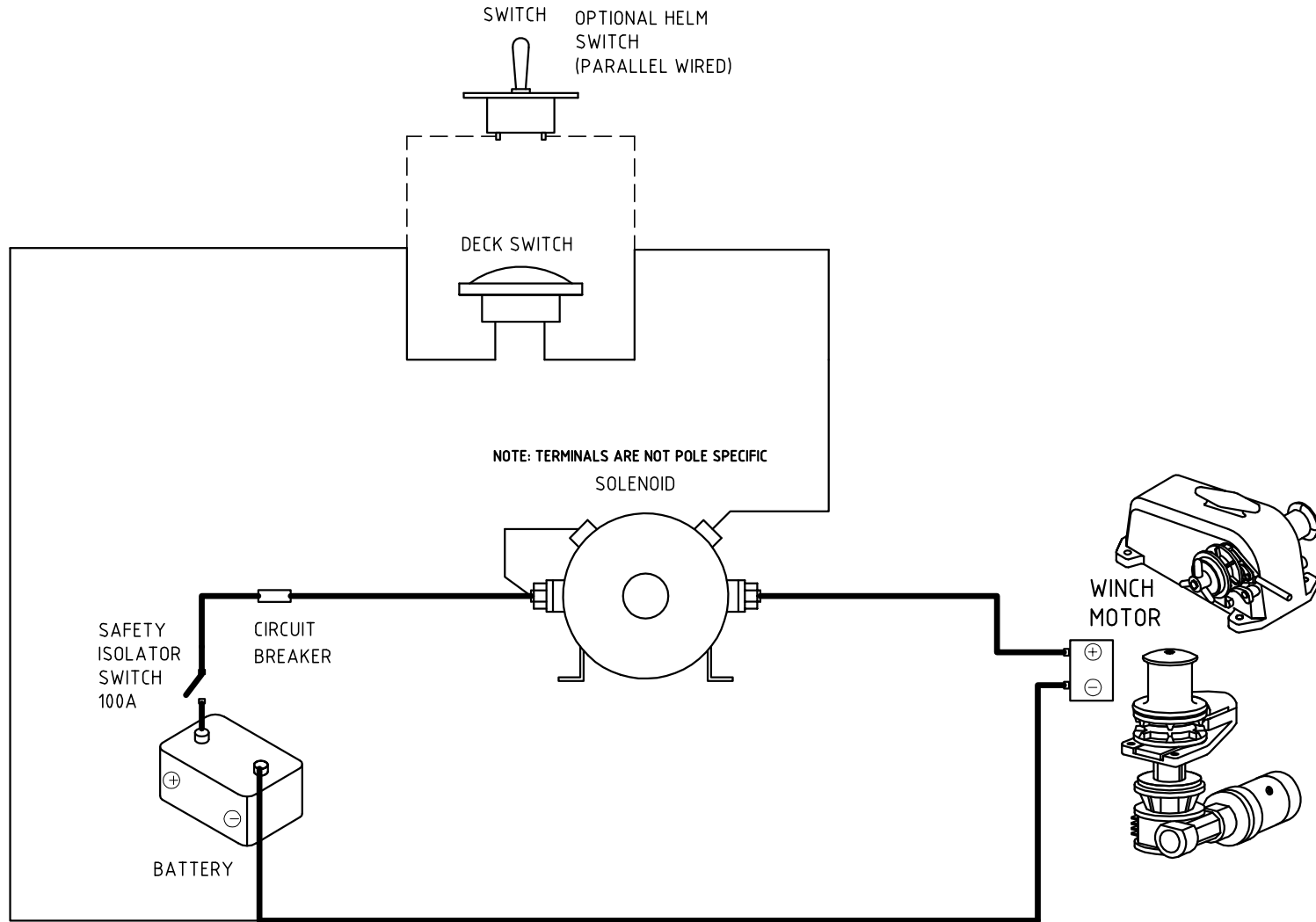
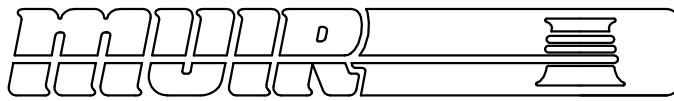

×HEAVY LINES INDICATE BATTERY CABLE. (HIGH AMP)
 LIGHTER LINES INDICATE WIRING. (LOW AMP)
 DASHED LINES INDICATE OPTIONAL WIRING



TITLE
 SINGLE SOLENOID, SINGLE DIRECTION, SINGLE SWITCH
 (NEGATIVE ACTIVATING)

PART No. WIRE0007 PAGE 2 OF 2

TOLERANCES (mm)	
X.	± 0.5
X.X	± 0.1
X.XX	± 0.025
UNLESS OTHERWISE SPECIFIED	
MATERIAL	
FINISH	

DRN SA	DATE 22/05/95	DRG No. WIRE0007
SCALE NTS	APP1	APP2
		SIZE A4

© COPYRIGHT MUIR ENGINEERING PTY. LTD. 3

G:\Acad\Wiring\WIRE0007.DWG, 18/11/2013 1:18:56 PM, pomas

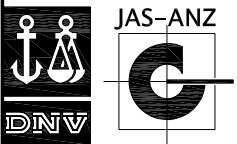

DNV Certification Pty Ltd
 Quality Assured
 ISO9001

REV No. 1	DESC. TABLES REMOVED	BY. PG	DATE. 18/11/2013
-----------	----------------------	--------	------------------

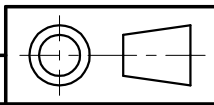

MAINTENANCE SCHEDULE

INSTALLATION	DATE	PROCEDURE
At Installation		See page 4/5
6 Months after installation		<ul style="list-style-type: none"> - Check all bolts are tight. - Check Grease tape/anti-corrosion film on Motor /Gear drive
12 months after installation		Remove chain wheel, clean cones then fully grease and lubricate. <ul style="list-style-type: none"> - see Maintenance & Servicing
2 years after installation		Remove chain wheel, clean cones then fully grease and lubricate. <ul style="list-style-type: none"> - see Maintenance & Servicing
3 years after installation		Remove chain wheel, clean cones then fully grease and lubricate. <ul style="list-style-type: none"> - see Maintenance & Servicing
4 years after installation		Full winch Service <ul style="list-style-type: none"> - All of the above - Drain and replace gearbox oil with 320 grade gear oil



Warranty Limited for period of Three years (First Owner)

We warrant each new product manufactured by us to be free from defects in material and workmanship for a period of 3 years (first Owner).

This warranty shall become effective only upon receipt of a completed warranty registration, which shall identify the product so registered by serial number. This warranty shall remain in effect for a period of three (3) years from the date of purchase.

For vessels in charter or hire the warranty is one (1) year due to various operators and overloading which may occur.

Conditions

While this warranty applies to defects in material and workmanship, it does not apply to:

- Normal worn parts or damage caused by neglect, lack of maintenance, accident or improper service/installation or service by persons other than an authorised Muir representative.
- Muir shall not be responsible for failures due to products being used in applications that are not intended for or exceed the products performance specifications.
- For warranty claim, defective product must be returned to Muir for inspection.
- Muir will not be responsible for freight charges, removal or installation labour on warranty claims.
- Damage due to unsatisfactory storage or use of equipment prior to installation in the approved/intended manner.

Exclusions

Warranty is limited to twelve months for:

- Electric motors / controls / equipment
- Hydraulic pumps / controls / valves
- Weather seals
- Use on charter/hire/commercial boats

All incidental and/or consequential damages are excluded from this warranty. Warranties of merchantability and fitness are excluded from this warranty. Implied warranties are limited to the life of this warranty. Some countries do not allow limitations on how long an implied warranty lasts or the exclusion or limitation of incidental or consequential damages, so the above may not apply to you.

We reserve the right to improve the design or materials used on any product without assuming any obligation to modify any product previously manufactured or used.

Liability

Muir Engineering liability under this warranty shall be to the exclusion of all other warranties or liabilities (to the extent permitted by law). In particular (but without limitation):

Muir Engineering shall not be liable for:

Any indirect or consequential loss including (without limitation) any loss of anticipated profits, damage to reputation or goodwill, loss of expected future business, damages, costs or expenses payable to any third party or any other indirect losses. Any damage to yachts or equipment. Death or personal Injury (unless caused by Muir Engineering negligence).

Please visit our website for more information and to register your product: <https://muir.com.au/support/warranty/>



BUILT TO LAST SINCE 1968 17





SCAN FOR MUIR WARRANTY



BUILT TO LAST SINCE 1968 18



Head Office:

100 Browns
Road Kingston,
Tasmania
Australia, 7050
Int Tel: +61 03 62290600
Email:
info@muir.com.au
www.muir.com.au

**Windlass:
Serial Number:**

Copyright 2023 Muir Engineering Group Pty Ltd.

Muir reserves the right to alter specifications without notice. All rights reserved.

While all care and attention has been taken in the preparation of this Manual, no responsibility shall be taken for error and omissions.

BUILT TO LAST SINCE 1968

